

УДК 372.853

DOI 10.25205/2541-9447-2020-15-1-108-138

**Первые интернет-олимпиады по физике
между объединенными российско-американскими
командами старшеклассников**

А. В. Аржанников, Б. А. Князев

*Новосибирский государственный университет
Новосибирск, Россия*

Аннотация

Статья посвящена двадцатилетнему юбилею проведения первых международных интернет-олимпиад по физике, организованных физическим факультетом Новосибирского государственного университета, в которых участвовали старшеклассники России и США. В те годы на рубеже столетий, оставалось еще несколько лет до появления популярных социальных сетей, а также не существовали ныне широко известные мессенджеры. По этой причине проведение таких соревнований было совсем не простой задачей как в организационном плане, так и в плане технической реализации. Кроме того, было необходимо преодолеть препятствие, связанное с большими различиями в образовательных программах и разным уровнем школьного преподавания физики в России и США, а также с наличием языкового барьера между участниками соревнований. Все эти препятствия были успешно преодолены совместными усилиями российского и американского организационных комитетов. В результате, в 1999 г. были проведены соревнования в рамках двух городов: Новосибирск и Сан-Диего, а в 2000-м – в рамках сети из четырех городов: Новосибирск – Санкт-Петербург – Сан-Диего – Сиэтл. Следует особо подчеркнуть, что весьма продуктивной оказалась идея проводить соревнования между командами, которые составлены из равного числа российских и американских школьников, общающихся между собой с помощью прямой видеосвязи. Это позволило выровнять шансы команд на победу и заменить межнациональное соперничество тесным сотрудничеством в рамках коллектива интернациональной команды. Комплекты олимпиадных задач были подготовлены как в форме обычных, письменных заданий, так и в форме видеоклипов, содержащих демонстрацию физического опыта. Видеоряд, демонстрирующий выполнение опыта по физике, удачно вписывался в решение проблемы преодоления языкового барьера. Безусловно, в полной мере был использован многолетний опыт, накопленный в НГУ при проведении всесибирских олимпиад и вступительных экзаменов по физике. В приложениях к данной статье, мы представили содержание заданий для участников олимпиад, а также отклики отечественной и американской прессы на описанные события.

Ключевые слова

преподавание физики, интернет-олимпиады, задачи по физике

Для цитирования

Аржанников А. В., Князев Б. А. Первые интернет-олимпиады по физике между объединенными российско-американскими командами старшеклассников // Сибирский физический журнал. 2020. Т. 15, № 1. С. 108–138. DOI 10.25205/2541-9447-2020-15-1-108-138

© А. В. Аржанников, Б. А. Князев, 2020

ISSN 2541-9447

Сибирский физический журнал. 2020. Том 15, № 1
Siberian Journal of Physics, 2020, vol. 15, no. 1

First Online Physics Olympiads between United Russian-American High-School Teams

A. V. Arzhannikov, B. A. Knyazev

*Novosibirsk State University
Novosibirsk, Russian Federation*

Abstract

The article is dedicated to the twentieth anniversary of two Internet physics olympiads organized by the Physics Department of Novosibirsk State University, in which senior pupils from Russia and the USA participated. For the time when before the advent of popular social networks there were a few more years when the currently popular messengers were not yet widespread, the organization of such competitions was technically and organizationally far from a trivial task. It was also necessary to overcome the problem of different programs and different levels of school physics teaching in Russia and the USA, as well as the problem of the language barrier. All these tasks were successfully solved by the joint efforts of the Russian and American organizing committees, and in 1999 the competitions Novosibirsk – San Diego and in 2000 Novosibirsk – St. Petersburg – San Diego – Seattle were held. A successful invention that allowed equalizing the chances of teams and replacing interethnic rivalry with cooperation was the idea to hold competitions between international teams, consisting of an equal number of Russian and American schoolchildren communicating with each other via direct video communication. Sets of tasks were prepared for the olympiads, both ordinary, written, and video clips with tasks-demonstrations. The latter have been particularly successful in resolving the problem of the language barrier. The great help in conducting these two Olympiads was the many years of experience gained by NSU during the All-Siberian Olympiads and the idea of the demonstration tasks used in entrance examinations at the Physics Department of NSU. We present in this article both the content of the tasks of the Olympiads and the responses of the domestic and American press to the events described.

Keywords

physics teaching, physics olympiads, tasks on physics

For citation

Arzhannikov A. V., Knyazev B. A. First Online Physics Olympiads between United Russian-American High-School Teams. *Siberian Journal of Physics*, 2020, vol. 15, no. 1, p. 108–138. (in Russ.) DOI 10.25205/2541-9447-2020-15-1-108-138

Вводные замечания

Весной 2019 г. исполнилось 20 лет с даты проведения Первой российско-американской интернет-олимпиады по физике (First USA / Russian Internet Olympiad on Physics) для выпускных классов средней школы. Проведение такой олимпиады для старшеклассников было предложено в ноябре 1998 г. в Новом Орлеане на ежегодной конференции Отделения физики плазмы Американского физического общества (Plasma Physics Division of APS) в ходе беседы Бориса А. Князева (заведующего кафедрой общей физики физфака НГУ) с Кэррол Даниэлсон и Ричардом Ли (Carol Danielson and Richard Lee from General Atomics) при участии Джона Виллиса из Департамента энергетики США (John Willis of the U.S. DOE). Основным препятствием к проведению этой олимпиады было то, что школьные программы по физике в Российской Федерации и США радикально отличались по глубине проникновения в изучаемый предмет и последовательности изложения образовательных материалов. Например, только в некоторых специализированных школах США описание физических законов в рамках образовательной программы проводилось с применением простых математических выражений. Осознавая это обстоятельство, приняли решение: создавать объединенные российско-американские команды, составленные из одинакового числа российских и американских старшеклассников. Это обеспечивало равенство возможностей для каждой из участвующих команд, а также способствовало развитию партнерских контактов между старшеклассниками двух стран.

Первая интернет-олимпиада по физике

Первая олимпиада была проведена 8–9 апреля 1999 г. при участии трех международных команд, каждая из которых была составлена из старшеклассников – представителей школ Новосибирска и Сан-Диего. Исключительно важной особенностью этих интеллектуальных соревнований было именно то, что каждая из трех команд представляла собой объединенный коллектив, составленный из 4-х российских и 4-х американских школьников. Эти две половины объединенной команды, состоящей из восьми человек, выполняли задание из 6-ти задач в условиях тесного общения с использованием интернет-технологий. С российской стороны в состав трех команд вошли старшеклассники трех школ города Новосибирска. В команду № 1 входили учащиеся физико-математической школы при НГУ (СУНЦ), в команду № 2 – учащиеся гимназии № 1 (Центральный район г. Новосибирска), в команду № 3 – учащиеся гимназии № 3 (Советский район г. Новосибирска). В свою очередь, с американской стороны в состав этих трех интернациональных команд вошли выпускники 5-ти школ, расположенных на территории города Сан-Диего. Здесь следует отметить, что в течение одной недели до начала соревнований учащиеся, входящие в состав каждой интернациональной команды с российской и американской сторон, вели интенсивное общение между собой по каналам связи, которые затем были использованы ими при совместном решении задач в ходе соревнования. В течение этой недели тренировок по общению на английском языке состав команды № 1 был несколько расширен как с российской (5 человек), так и с американской стороны (7 человек). Это нашло отражение на фотографиях трех интернациональных команд (рис. 1). Во время соревнований команда № 1 имела в своем составе 8 обучающихся (по 4 человека с каждой стороны), как и две другие интернациональные команды.

Задание для этой интернет-олимпиады было составлено программным комитетом, образованным из представителей именно тех трех среднеобразовательных школ, учащиеся которых входили в состав соревнующихся команд с российской стороны. На рис. 2 представлена фотография, полученная во время рабочего заседания этого комитета. Здесь же, несколько правее фотографии программного комитета, представлена фотография профессора Б. А. Князева, который ведет разговор с американскими коллегами непосредственно во время проведения соревнования с целью координации действий между организаторами с российской и американской сторон.

В задании, выданном участникам данного соревнования, содержалось шесть задач, тексты которых представлены в приложении 1 и сопровождаются решениями, что позволяет читателям данной статьи оценить доступность решения всего задания на базе знаний школьной программы. При выставлении полного числа баллов, набранных каждой из трех команд по результатам выполнения ими предложенного задания, программный комитет оценивал результат решения каждой из задач в баллах в зависимости от того, насколько представленное командой решение смогло приблизиться к достижению соответствующего ответа. По результатам проверки представленных командами решений первое место в соревновании заняла команда № 2, в которую с российской стороны входили учащиеся гимназии № 1, второе место было присуждено команде № 3, включающей учащихся гимназии № 3, и, наконец, третье место заняла команда № 1, состоящая из учащихся СУНЦ.

Проведение Первой интернет-олимпиады школьников вызвало большой интерес как российских, так американских средств массовой информации (см. прилож. 2 и 3) и нашло отражение в интернет-сообщении¹. В прилож. 3 представлен один из примеров публикации об Олимпиаде в американской прессе, а именно статья в газете *The Daily Californian*.

¹ <https://www.aps.org/publications/apsnews/199908/internet-olympiad.cfm>



Рис. 1. Команды – участницы Первой интернет-олимпиады. Объединенные российско-американские команды представлены в последовательности сверху вниз в соответствии с занятыми местами по итогам соревнования

Fig. 1. Teams – participants of the First Internet Olympiad. The united Russian-American teams are presented in a sequence from top to bottom in accordance with the occupied places following the results of the competition

Members of the Russian Program Committee

Originator of US/Russian Olympiad



(left to right): **Yurii Bashkatov, Educator of Gymnasium #3;**
Anatolii Trubachev, Educator of SPM;
Andrey Arzhannikov, Professor NSU, Chairman;
Ivan Vorob'ev, Associate professor of SPM;
Idris Agliulin, Educator of gymnasium #1
 Man standing behind Arzhannikov, is **Alexander Ershov, Associate Professor of SPM**

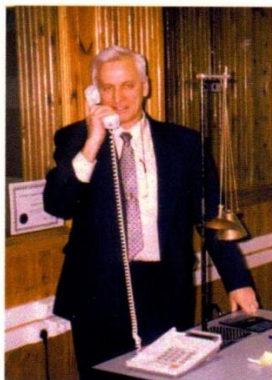

Boris A. Knyazev

Рис. 2. Программный оргкомитет Первой интернет-олимпиады с российской стороны
Fig. 2. Program Committee of the First Internet Olympiad from the Russian side

Вторая интернет-олимпиада по физике

Благодаря широкому распространению информации о Первой интернет-олимпиаде по физике на участие в интернет-олимпиаде следующего года подали заявку представители школ уже из четырех городов. Наряду с Новосибирском и Сан-Диего к участию в олимпиаде присоединились Санкт-Петербург (учебный центр академика Ж. И. Алфёрова) и Сиэтл (рис. 3). В этом, втором, соревновании участвовало восемь интернациональных команд, составленных из учащихся российских и американских школ. В каждую команду входили по одной школе из России и из США. Схема, по которой была организована совместная работа школьников, входящих в одну интернациональную команду, при решении задач, а также схема

взаимодействия четырех судейских команд, работавших в четырех городах, по оценке качества решения задач, предложенных в задании, нашли отражение на рис. 4.



Рис. 3. Четыре города из двух стран – участники Второй интернет-олимпиады
 Fig. 3. Four cities from two countries – participants of the Second Internet Olympiad

Задачи для данной олимпиады были составлены российским программным оргкомитетом и согласованы с американскими коллегами на предмет соответствия содержанию образовательных программ. В приложении 4 последовательно представлены задания на первый (подготовительный) тур, в ходе которого участники команд осваивали методику совместной работы над решением задач с использованием интернет-коммуникации, и на второй (заключительный) тур, по результатам которого осуществлялось распределение команд по местам в турнирной таблице.

Пример трансляции через Интернет практической задачи, которая была включена в задание на заключительный тур, в виде фильма, демонстрирующего опыт по физике из школьной программы, представлен на рис. 5.

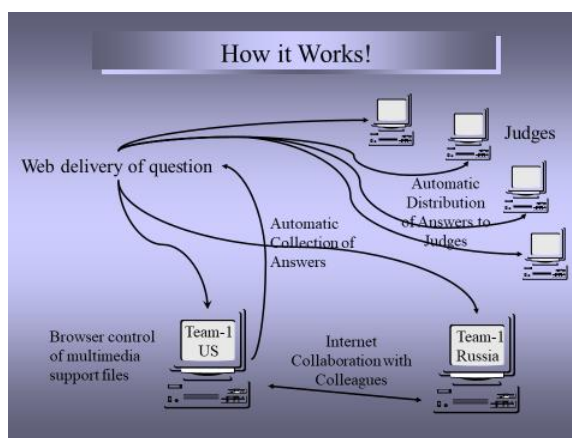

Рис. 4. Схема сети, обеспечивавшей связь школьников в совместных командах и членов жюри в четырех городах

Fig. 4. Schematic of the network providing communication for the school students in the joint teams and for the jury members in four cities

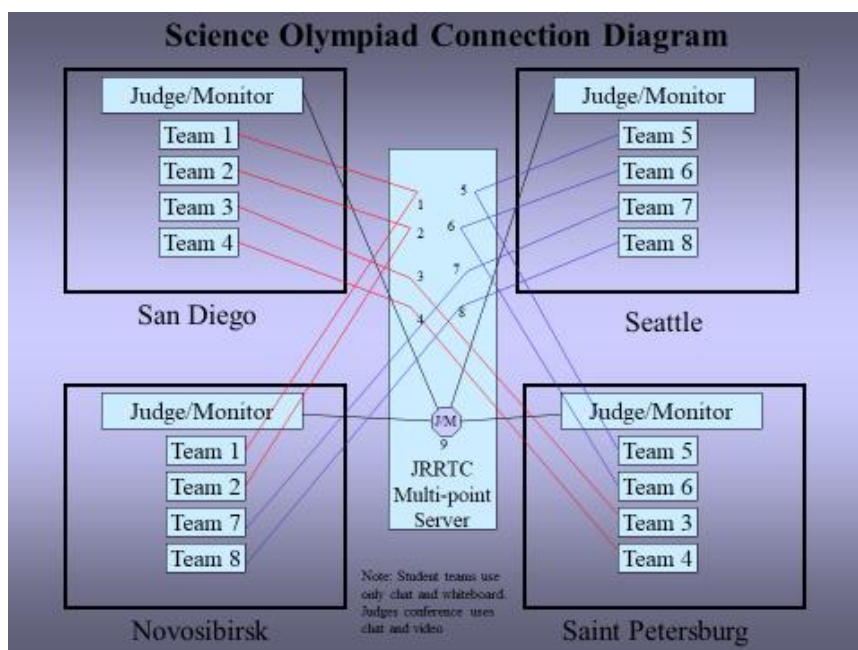

Рис. 5. Изображение экрана компьютера каждой из команд, на котором демонстрируется физический эксперимент, требующий объяснения наблюдаемого явления

Fig. 5. The image of the computer screen of each of the teams, which displays a physical experiment that requires an explanation of an observed phenomenon

Учащиеся российских и американских школ активно обсуждали решения задач с использованием предоставленных интернет-технологий: chat и white board (рис. 6). В свою очередь, судейские команды использовали также две взаимно-дополняющие технологии: chat и vide-conference (рис. 7). С позиции сегодняшнего дня, указанные интернет-технологии выглядят совсем не впечатляюще, но в те далекие годы (конец девяностых) этот процесс связи считался уникальным техническим решением.

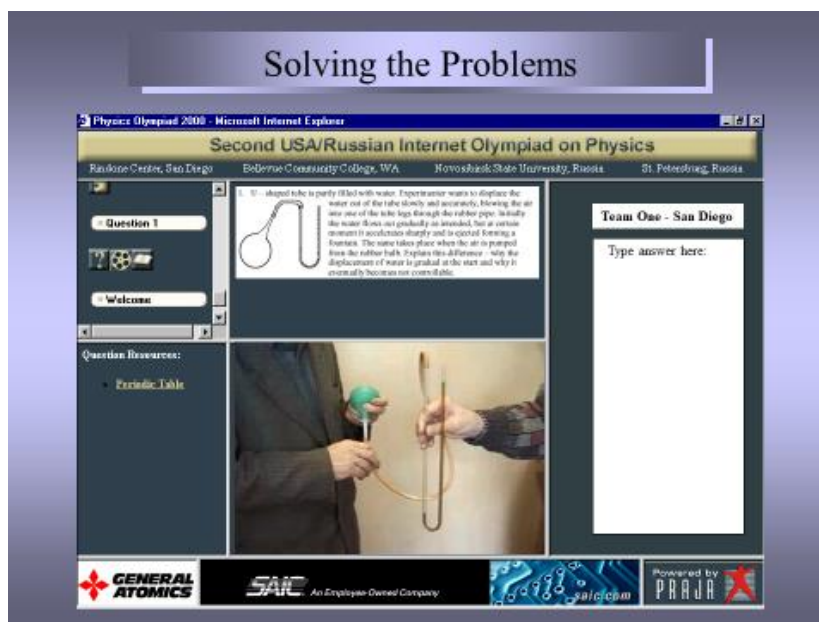

Рис. 6. Работа объединенных команд над решением задач в условиях неотступного контроля со стороны международного жюри
Fig. 6. Joint teams work on problem solving in the conditions of constant control by the international jury



Рис. 7. Активная работа жюри в ходе проведения заключительного тура соревнований и при выработке итогового решения по результатам этого тура
Fig. 7. Active work of the jury during the final round of the competition and in the development of the final decision on the results of this round

Используя интернет для тесного динамичного общения, международное жюри, составленное из представителей всех четырех городов, детально проанализировало решения, представленные восемью командами. Итоговая таблица с результатами проведенного соревнования представлена на рис. 8. Видно, что международное жюри присудило победу команде № 1, которая была составлена из учащихся СУНЦ НГУ (г. Новосибирск) и трех школ из города Сан Диего. Эта команда набрала 43,25 балла. Второе и третье места поделили между собой команда № 5 и 6, набравшие по 37 баллов. Списочный состав команд-победительниц представлен на рис. 9. Проведение Второй интернет-олимпиады нашло широкий отклик в средствах массовой информации. Пример публикаций по этому поводу представлен в приложении 5.

International Internet Physics Olympiad

[Home](#) | [Rules](#) | [Practice Problems](#) | [Participant Chat](#) | [Contest site](#)

Here are the final results for the competition. The competition organizers extend their congratulations to all the contestants. You have confronted tough physics problems under demanding conditions and have all proved your worth. As you can see below, Team 1 takes first place, followed by a tie for second/third place between teams 5 and 6. Our special congratulations to these teams!

Look for the problems, answers, and scoring rubrics using the links below the table.

Final Results of the Competition

Team	Team 1	Team 2	Team 3	Team 4	Team 5	Team 6	Team 7	Team 8
Prob.	S.D./Nsb.	Nsb./Sea.	Nsb./S.D.	Nsb./Sea.	S.D./St.P.	Sea./St.P.	St.P./S.D.	St.P./Sea.
1	9	6	6	5	7	5	4	4
2	10	5	3	4	5	10	5	10
3	2.5	1	1.5	4	2	4	4	1.5
4	7	3	4	7	6	8	2	4
5	8	2	5	5	7	0	2	3
6	6.75	7	10	6.75	10	10	10	10
Total	43.25	24	29.5	31.75	37	37	27	32.5
Standing	1	8	6	5	2-3	2-3	7	4

S.D. = San Diego, Nsb. = Novosibirsk, Sea. = Seattle, St. P. = Saint Petersburg

BCC Website

<http://scidiv.bcc.ctc.edu/physics/ipof/finalscore.html>

Рис. 8. Итоги финального тура Второй интернет-олимпиады по физике
Fig. 8. The results of the final round of the Second Internet Physics Olympiad

US-Russian Physics Olympiad on the Internet
Thursday, April 27, 2000/
Friday, April 28, 2000

WINNERS

First Place: Team 1

Sergei Shepelenko	Novosibirsk	Phys/Math School*
Dmitrii Sidorov	Novosibirsk	Phys/Math School *
Roman Lavrov	Novosibirsk	Phys/Math School *
Dmitrii Maljutin	Novosibirsk	Phys/Math School *
Ms. Liu Yang	San Diego	La Jolla High
Chris Lyons	San Diego	Poway High
Henry Fei	San Diego	Patrick Henry High
Marko Cetina	San Diego	Eastlake High

Tied for Second Place: Teams 5 and 6

Team 5:

A. J. Vincent	San Diego	La Jolla High
Jon Novak	San Diego	Poway High
Kaiya Tollefson	San Diego	Patrick Henry High
Anais Lim	San Diego	Eastlake High
Dmitry Semyonov	St. Petersburg	Physico-Technical School, Ioffe Institute
Aleksandr Nesteryonok	St. Petersburg	Physico-Technical School, Ioffe Institute
Iliya Posov	St. Petersburg	Physico-Mathematical Lyceum #239
Rodion Myasnikov	St. Petersburg	Physico-Mathematical Lyceum #239
Andrey Kokorin	St. Petersburg	

Team 6:

Eric Lam	Seattle	Inglemoor High
Edgar Lobaton	Seattle	Sammamish High
Adam Neugebauer	Seattle	Redmond High
Mark Davenport	Seattle	Issaquah High
Sergey Simonov	St. Petersburg	Physico-Mathematical Lyceum #239
Grigoriy Fishman	St. Petersburg	Physico-Mathematical Lyceum #239
Dmitriy Semikin	St. Petersburg	Physico-Mathematical Lyceum #239
Mikhail Raer	St. Petersburg	Physico-Mathematical Lyceum #239
Sergey Lebedev	St. Petersburg	Physico-Mathematical Lyceum #239
Kiril Voroshilov	St. Petersburg	Physico-Mathematical Lyceum #239

* School newly renamed: Scientific Study Center at Novosibirsk State Univ.

Рис. 9. Российско-американские команды, занявшие призовые места во Второй интернет-олимпиаде по физике для старшеклассников
Fig. 9. Russian-American teams that won prizes at the Second Internet Physics Olympiad for high school students

Заключение

Таким образом, впервые в истории проведения международных олимпиад была применена нарождающаяся методика проведения предметных олимпиад для школьников различных стран с использованием интернет-технологий. Как было отмечено, основная трудность в организации соревнований между старшеклассниками российских и американских школ состояла в том, что глубина изложения учебного материала по физике и порядок его изложения

по образовательной программе сильно различаются в двух странах. Если исходить из аналогии со спортивными соревнованиями, получается так, что приходится сопоставлять результаты, достигаемые командами, составленными из двух категорий легкоатлетов: участников, прыгающих в высоту со спортивным шестом, и участников, довольствующихся прыжком через перекладину. В случае, когда при оценке достигнутого командой результата суммируются значения высоты, преодоленной каждым из членов команды, получается, что основной вклад в достижение внесут прыгуны с шестом. В американских общеобразовательных школах учат физике так, что это соответствует прыжкам через перекладину на высоте 1,5 метров, и наши зарубежные коллеги приняли решение не проводить далее соревнований между командами, в которых объединены российские и американские школьники. Получалось так, что при обсуждении в команде задачи, предлагаемой олимпиадным заданием, правильное решение, как правило, предлагали российские школьники, а американские члены этой команды только пытались разобраться в предлагаемом россиянами решении. В этих условиях страдало самолюбие американских партнеров, и в итоге это привело к тому, что американская сторона отказалась от проведения интернет-олимпиад в последующие годы.

С той поры, когда проходили описанные в данной статье первые интернет-олимпиады, прошло 20 лет. За эти годы возможности, предоставляемые интернет-технологиями для общения людей в масштабах всего земного шара, неизмеримо выросли. Учитывая то обстоятельство, что уровень преподавания физики в школах таких европейских стран, как Германия и Франция, не уступает российским школам, представляется весьма полезным организовать соревнования школьников в пределах Евразии, используя уникальные современные возможности Интернета. Целесообразно также обратить внимание на возможность проведения соревнований по физике с использованием Интернета между учащимися школ и студентами первых двух лет обучения в университетах нашего региона или всей России. Это, несомненно, повысило бы общий уровень освоения физики в этих учебных заведениях, что принципиально важно для подъема уровня инженерного образования в Российской Федерации.

Мы искренне благодарны коллегам по Программному комитету интернет-олимпиад по физике: Ивану Воробьеву, Александру Ершову и Анатолию Трубочеву, которые в те годы преподавали физику в СУНЦ при НГУ, а также Идрису Аглиулину и Юрию Башкату, работавшим учителями физики соответственно в гимназиях № 1 и 3 г. Новосибирска. Особо отметим важную роль в проведении интернет-олимпиад наших партнеров с американской стороны: Кэрл Даниэльсон (Carol Danielson) и Ричарда Стефенса (Richard Stephens) из Джeneral Атомикс.

Олимпиада была проведена при поддержке со стороны Новосибирского государственного университета, программы «Интеграция науки и образования» (грант № 276) Министерства образования РФ, Министерства энергетики США (Department of Energy), компании «Дженерал Атомикс» (General Atomics) и Технического центра им. Джо Риндона (Joe Rindone Technical Center). В организации второй олимпиады принял активное участие Научно-образовательный центр (НОЦ) Физико-технического института имени А. Ф. Иоффе РАН, созданный Нобелевским лауреатом по физике Ж. И. Алфёровым. Авторы выражают благодарность коллегам из НГУ и НОЦ: Т. Е. Алексеевой, С. В. Быкову, Н. С. Диканскому, Ю. М. Зыбареву, А. И. Живоглядову, В. Н. Иванченко, А. А. Киприянову, К. Г. Костенко, И. А. Котельникову, Б. В. Кутееву, Д. В. Литвиенко, Г. В. Меледину, В. А. Мельничуку, А. А. Никитину, С. Н. Нужину, Е. И. Пальчикову, В. В. Радченко, В. С. Серебрянскому, А. Е. Турину, Е. Н. Фаддеенкову, В. С. Черкасскому, Ш. Р. Яхину, а также американским партнерам: П. Винтеру (P. Winter), Д. Брауну (D. Brown), С. Гамильтону (S. Hamilton), Д. Эдлеру (D. Edler), Б. Симпсону (B. Simpson), Р. Ли (R. Lee), Ю. Омельченко (Yu. Omelchenko), Дж. Уиллису (J. Willis), Р. Хоббсу (R. Hobbs) за весомый вклад в организацию и проведение двух российско-американских интернет-олимпиад.

Задачи, предложенные к решению
участникам Первой интернет-олимпиады по физике

Questions and Answers for Olympiad (real, 4/8/99)

Problem # 1

A pendulum is installed on a small platform which has four wheels. This construction is placed on the horizontal table. The rear end of a platform is lifted up slightly and rests on a piece of foam plastic so that two rear wheels do not touch the table. A man swings the pendulum pulling it by the thread in a backward direction. After the amplitude of oscillations becomes large enough, all apparatus moves forward. What causes this paradoxical behavior?

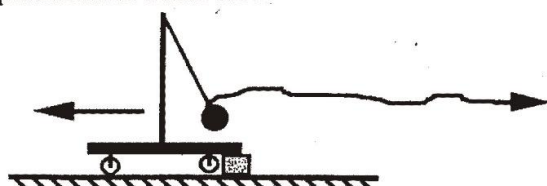

Answer #1

The tension of the oscillating pendulum creates a torque trying to turn the platform within the plane of oscillations (to lift the end opposite to the pendulum's deflection). As far as the platform remains horizontal, this action is compensated by different reaction forces applied to wheels and foam plastic. So the reaction force is greater at that side to which the pendulum is deflected. The maximal friction is proportional to the reaction force.

Problem # 2

The cylinder, which has a small opening in a bottom end, is filled with water by immersing it in bucket. A piston is put in the cylinder under the water. Then the system is raised so that only the bottom remains in the water. Finally the piston is drawn up sharply. For a short time the space under the piston is filled with bubbles (appears frothy), but in a matter of a second the transparency and homogeneity are restored. Choose the leading mechanism of this phenomenon:

Answer # 2

The cross-section of the cylinder is about ten square cm. So the force needed to reduce the pressure inside to zero is about 10 kG, or 25 pounds, or 100 N. Almost everybody can do it. As the pressure falls down to less than 14 mm Hg, the water starts to boil at room temperature. When the water coming through the bottom opening fills the enlarged volume, the pressure returns to the normal level and the steam condenses back into water. About other answers: d is wrong since the water is present above the piston (and effectively serves as sealing). The effects of dissolved gas and of the embryo air bubbles are comparatively minor. There is naturally more water vapor at hand than of dissolved gas (and than of gas bound in micro-bubbles) to fill the bubbles. Actually one can see that about 1 cubic cm of gas appears in the upper part of cylinder when the pressure is restored. This gas came partly from embryo bubbles or partly was dissolved. But its

separation from water and its presence under the piston does not affect the next experiments.

Problem # 3

Two point charges $2Q$ and Q are fixed at the opposite ends of a rod whose length is $2L$. A rod can freely rotate about its center. A third charge Q is carried from infinity along the line continuing the rod from the side opposite to $2Q$. At which distance between third Q and the axis the rod will start to rotate?



- α) $4L$
- β) $13L/2$
- γ) $L\sqrt{15}$
- δ) $L(\sqrt{2} + 1)/(\sqrt{2} - 1)$
- ε) $17L/(2 + \sqrt{3})$

Answer #3 - δ

The answer used at the time of the experiment was calculated by finding the position of the third charge for which the forces on the other two were equal: At large distances the rod is stable because the force acting on (repelling) $2Q$ is about two times larger than the force on $1Q$. When the force on $1Q$ becomes larger, the equilibrium becomes unstable and a small deflection of the rod will increase. The critical situation corresponds to equal forces: $2Q^2/(x+L)^2 = Q^2/(x-L)^2$. This gives δ.

After the competition was over, we found a mistake in the argument.

Since we are asking for a rotation, we should equate torques, not forces. To see what this does, rotate the rod a very small angle α . The torque is the product of the force, pivot distance, and the angle between the rod and force directions. That angle is different for the two charges. The correct equation is:

$$2Q^2/(x+L)^2 \times (\alpha - \alpha L/(x+L)) = Q^2/(x-L)^2 \times (\alpha + \alpha L/(x-L))$$

It reduces to:

$$2/(x+L)^3 = 1/(x-L)^3$$

and the right result is

$$x = L \frac{(2^{1/3} + 1)}{(2^{1/3} - 1)}$$

that is, replace the square roots in δ with cube roots. Note, that this system is in unstable equilibrium – the rotating torque is zero if the rod angle is exactly zero.

Problem # 4

Given three sealed containers of equal volume of 1 atmosphere of air. Ignite a lump of coal in one, magnesium ribbon in a second, and immerse the third in liquid nitrogen. Let

the first two come back to room temperature after the burning stops. What is the change in the number of gas molecules, and the mass of the gas in each container.

α.

Container no.	1	2	3
gas molecules numb.	no change	reduced by 20%	no change
mass of gas	increased by 10%	reduced by 20%	no change

β.

Container no.	1	2	3
gas molecules numb.	reduced by 20%	reduced by 20%	reduced by 80%
mass of gas	reduced by 20%	reduced by 20%	reduced by 77%

γ.

Container no.	1	2	3
gas molecules numb.	no change	increased by 40%	no change
mass of gas	increased by 10%	increased by 20%	no change

δ.

Container no.	1	2	3
gas molecules numb.	no change	reduced by 20%	reduced by 20%
mass of gas	increased by 10%	reduced by 20%	reduced by 20%

Answer #4 - α

Burning carbon converts the O₂ in the air (20%) to CO₂ also a gas. The number of molecules of gases resulting from the burning is the same as original. The weight has increased. C is nearly as heavy as O, so the CO₂ is 50% heavier, and the total atmosphere is about 10% heavier. b) burning magnesium produces a solid. The number of molecules is reduced by 20% as is the atmospheric weight c) cooling to 77K reduces the pressure to 77/300 atmosphere, for a 70% reduction in pressure. However, the gas inside the volume won't liquify because of the low pressure. Both the mass of gas and the number of molecules inside the container is the unchanged. There is a small amount of both CO₂ and H₂O in air. These will both condense in the third container, but that causes only an insignificant change in the mass and number of gas molecules in that container.

Problem # 5

Find the sum of the first 1000 coefficients in an expansion of

$$(1+x)^{1999} = 1x^0 + 1999x^1 + \dots + 1999x^{1998} + x^{1999}$$

α) 1000!

β) 500500

$$\gamma) 2^{1998}$$

$$\delta) \frac{1999!}{1000!999!}$$

$$\epsilon) 3^{1999}$$

Answer #5 – γ

Let us set $x=1$. Then the binomial is $(1+1)^{1999} = 2^{1999}$. The sum in question is half of this value (since there is exactly 2000 terms in an expansion).

Problem # 6

If 1000! is written out, how many zeros will be at the end?

$$\alpha) 15$$

$$\beta) 168$$

$$\gamma) 233$$

$$\delta) 249$$

$$\epsilon) 317$$

$$\phi) 1227$$

Answer #6 – δ

Each zero represents a factor of $10 = 2 \cdot 5$. The number of zeros will be given by the lesser of the number of 2 factors or 5 factors in this product. First look at number of 5s. $1000/5 = 200$ will have one factor of 5, $1/5$ of those ($1000/25 = 40$) will in addition have a second factor of 5, $1/5$ of those ($1000/125 = 8$) will have three factors, and 1 ($1000/625 = 1$) will have four. Total = 249. Apply the same reasoning to 2s and see there are many more of those. So there will be 249 zeros

Приложение 2

Доклад на конференции с информацией о проведении Первой интернет-олимпиады между командами, в которых объединились российские и американские старшеклассники

*Oral presentation at the International Conference
"PHYSICS IN THE SYSTEM OF MODERN EDUCATION" (PSME-99)
21–25 June, 1999, Saint Petersburg, Russia*

**First International Novosibirsk – San Diego Physics Olympiad:
Integration of Physics and New Information Technologies**

A. V. Arzhannikov, I. I. Vorobiev, A. P. Ershov, A. A. Kipriyanov, B. A. Knyazev,
K. G. Kostenko, G. V. Meledin, S. N. Nuzhin, E. N. Faddeenkov
Novosibirsk State University, 630090 Novosibirsk, Russia

C. Danielson, R. Stephens
General Atomics, San Diego, CA 92121

D. Elder, B. Simpson
Joe Rindone Technical Center, San Diego County Office of Education

The goal of the Olympiad over the internet was to develop the principles and technology of conducting competitions in “real time” as a model of joint professional activity of participants separated by large distances. Interrelation of technical means and academic methods, eventually, significantly determined the format and the ways to conduct the Olympiad.

To equalize the start-up conditions, three mixed teams of Russian and U.S. high-school graduate students were formed. Three weeks before the event, the students had an opportunity to meet each other by email. The Olympiad was held in video-conference centers which provided audio-visual contact between two audiences located on different continents. The computers of the “halves” of each international team were linked by NetMeeting, a program that allows communication in chat and white-board regimes. The two halves of the international jury also communicated via NetMeeting, had a table display of current results, and used the telephone.

The Olympiad started on the morning of April 9, 1999 (April 8, p.m., San Diego time) with opening welcome remarks by Dr. Robert Conn, Dean of School of Engineering, UCSD, and Dr. N.S. Dikanskii, Member-Correspondent of the Russian Academy of Sciences, Rector of the Novosibirsk State University. The Olympiad consisted of 6 tasks, each scored by up to 2 points each. The first two tasks were demonstrations of physical phenomena; they were pre-recorded digitally and displayed for the competitors on the computer screens. Other tasks were typical assignments in physics and math. While tasks-demonstrations required qualitative explanations, other tasks were scored by the test system. After a ten-minutes’ discussion over the internet, each half of the team would provide an answer to the jury. In two minutes, the international jury would rate the answer of each team and announce the result. The winning team (students from Novosibirsk school No. 1 and their U.S. partners) led with 11 points out of 12 possible while two other teams (school No. 130 with American partners and physical-mathematical school under NSU with the American partners) scored 10 points each.

The experiment showed that Olympiads in the sciences over the internet are technically feasible and appropriate. Internet is most effective when the competitors are located far apart but have to

work out a common decision. Technologies such as NetMeeting (GoogleMeet, Zoom, etc.) can provide the necessary level of interaction among participants during a competition. This kind of communication also can be useful for partners in scientific research and for editing scientific articles. Internet connection at intercontinental distances is not 100%-reliable yet, so a parallel way to conduct such competitions should be provided.

The Olympiad was supported by the Novosibirsk State University, program “Integration of science and education” (grant N 276), Department of Energy, General Atomics, and Joe Rindone Technical Center. The authors express their gratitude to I. Sh. Agliulin, T. E. Alekseeva, Yu. L. Bashkatov, S. V. Bykova, N. S. Dikanskii, Yu. M. Zybarev, A. I. Zhivoglyadov, V. N. Ivanchenko, I. A. Kotelnikov, D. V. Litvienko, V. A. Melnichuk, A. A. Nikitin, V. V. Radchenko, V. S. Serebryanskii, A. E. Turin, Sh. R. Yahin as well as C. Danielson, R. Stephens, C. Hamilton, R. Lee, Yu. Omelchenko, J. Willis, P. Winter for their assistance in organization and conducting of the Olympiad.

Статья в *The Daily Californian* с информацией о проведении Первой интернет-олимпиады по физике между объединенными командами, составленными из российских и американских старшеклассников

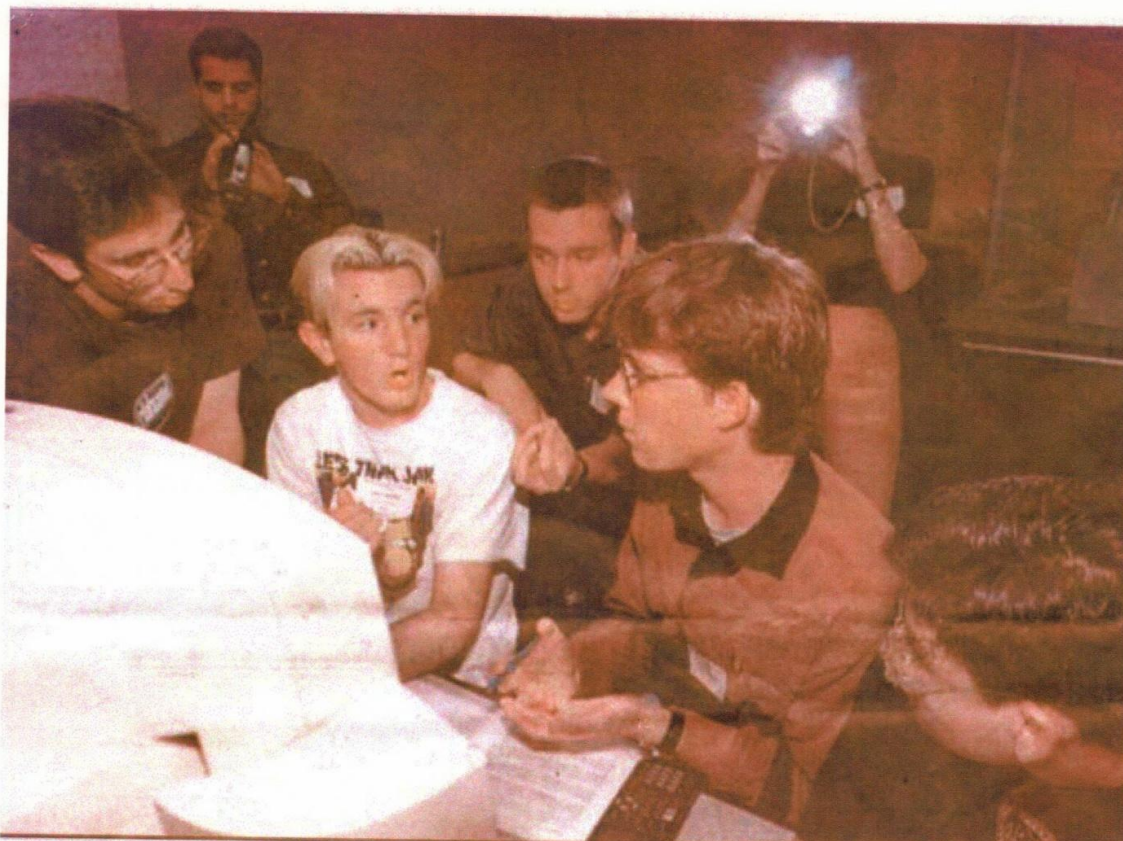

Members of a hybrid high school team in the international Physics Competition confer during the event. Participants (from left) are Ross Moskowitz (Grossmont), Brian Appleby (Kearny), T.J. Heibel (Grossmont), Paul Kolinko (Torrey Pines) and David Sallie (Kearny).

Teens battle over physics

By Carey B. Stone
Daily Californian staff writer

A select group of county high school students joined a similar band from Russian Siberia Thursday night to engage in an activity that would have been unthinkable 20 years ago — competing as teammates in an International Physics Olympiad.

Physics students from Grossmont, Bonita Vista, Kearny, Mira Mesa and Torrey Pines high schools gathered at the

county Office of Education's Joe Rindone Regional Technology center and connected via Internet with their Siberian counterparts.

Each of three teams consisted of American students partnered with students from the University of Novosibirsk, who likewise sat clustered around three computers.

Moderators in both countries gave the students physics, math and chemistry problems that the mixed

Please see **PHYSICS**, page A6

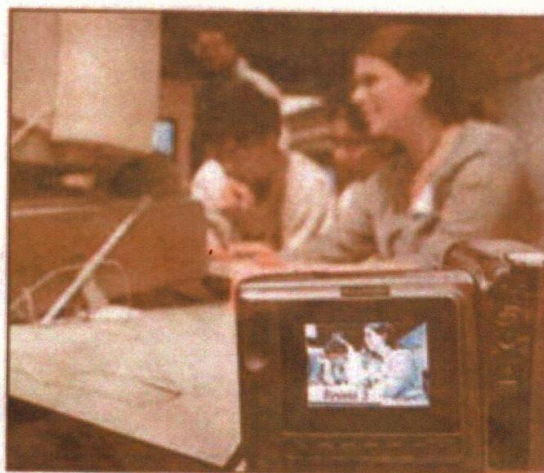

A video image of Grossmont High School student Adam Grindles is transmitted via the Internet during the competition.

The Daily Californian

The Voice of East San Diego County



FRIDAY
APRIL 9, 1999

PHYSICS

continued from page A1

teams worked on both separately and together.

The Russian and American students of Team 1, for example, worked separately to try to answer the question, "If 1000! is written out, how many zeros will be at the end?" Then the entire team discussed both answers before turning them into the moderators.

Both parts of Team 1 got right answers, so the team received two points. Had only one half of the submitted the correct answer, the team would have received one point.

"It's a lot more challenging (than anything in school) but it's kind of fun to work with a group of people to figure out the solutions," said Grossmont's Colin Means of Team 3.

Tom Eklund, Mean's physics teacher, said it was good for his students to work together with others in the county and in Siberia.

"This type of competition is more common in Russia and Eastern Europe," Eklund said. "We're seeing more competitions in the U.S. in the last 10 to 15 years, which cover a lot of academic subjects, but Russia has been focused on science competitions for about 50 years."

The Olympiad was the brainchild of Boris Knyazev, chairman of physics education eastern Russia, who suggested the idea in November to some American physicists at a conference. He wanted to spread the tradition of physics competitions to the U.S., said Richard Stephens of the Fusion Group at General Atomics, who organized the San Diego portion of the event.

The event was sponsored by General Atomics, the Department of Energy's Office of Fusion Energy Sciences and Novosibirsk State University,

and the County Office of Education provided space for the event.

At times, the San Diego students could see their Siberian counterparts through an Internet-relayed video on a big screen at the front of the room, but often the connection was not stable. Students wrote to each other and drew diagrams on graphic tablets, or white boards, attached to the computers.

After about two hours the squeals and giggles of success began emanating from the table in the middle of the room, peopled by the excited young scientists of Team 2. They and their Siberian counterparts won the competition with 11 points — and the other teams finished with 10 points each.

Students of both countries will share a \$3,000 prize provided by General Atomics and the Department of Energy. Half the money will be divided by the San Diego members of Team 2— Adele Grundies of Grossmont, Michael Brening of Torrey Pines, Phong K. Kieu of Mira Mesa and JJ Cherry of Bonita Vista High School. The other \$1,500 will be split among Russian students Alexei Reznichenko, Alexander Babenko, Andrei Chuguev and Evgenija Fichman.

Grundies and Kieu said that they and their Siberian partners had similar levels of education in physics, but with strengths and weaknesses in different areas. Cherry said that the same was true for physics students from the different schools in San Diego.

Asked to compare the thrill of winning this competition with that of winning a soccer game, Brening said he preferred the physics competition.

"You can win a lot of soccer games, but this is my first Physics and Math Olympiad," he said.

Задачи Второй интернет-олимпиады по физике

Задание на первый тур

Questions and Answers to the Practice Competition

1. Question: One end of a rubber cord is fixed. The band is stretched so that the other end is a bit higher. A small plastic ringlet hangs on the cord. A pencil is fastened to the higher



end. Experimenter takes this end in his right hand, pulls the cord a bit further, then releases it. The band contracts until the pencil, hitting the left hand of the experimenter, stops the contraction. When this procedure is done repeatedly, the ringlet crawls upwards along the band. Why does the ringlet go up, against gravity?

- When the cord is released, standing waves develop which push the object from the antinode to the nearest node.
- During the slow stretching aerodynamic drag is not significant. During the fast return air creates appreciable resistance.
- The object produces a local flexure in the cord. This flexure pulls the object if the cord moves slowly. Upon the fast return the object lags behind the cord, jumping out of flexure.
- On slow stretching, the acceleration of the object by the cord is less than A -- the value which might be produced by friction. Contrary, upon return the band acceleration is greater than A .

1. Answer: d) The acceleration of the cord under the object is less than A - the value which might be produced by friction. Contrary, upon return the band acceleration is greater than A .

The ringlet is kept in position by the frictional force between the ringlet and the cord. The frictional force resists the sliding of the ringlet on the cord, but it has a maximum value determined by the coefficient of friction. When you pull on the cord, or release it, the location under the ringlet moves. In order for the ringlet to follow, it must be accelerated from rest to some velocity V in the time T it takes to initiate pulling. If the ringlet is to follow this motion, the force which accelerates it, $F_a = m V/T$, must be less than the maximum frictional force given by $F_f = \mu mg$, where μ is the coefficient of friction. This is possible for the slow stretch, so the ringlet rides up as the cord stretches. Not possible for the fast return, so it (almost) stays put while the cord slides back underneath it.

2. Question: Some hot water is poured into the large glass jar. The rubber glove is put on the jar neck. When the jar is shaken, the glove inflates, standing up, then slowly flattens. The process may be repeated several times. Explain this phenomenon.

a) Shaking produces bubbles, effectively boiling the water. The steam inflates the glove. When the steam is cooled, it condenses and the glove deflates.

b) According to Bernoulli's law, the pressure decreases if the liquid velocity increases. So the moving water really boils and the steam inflates the glove. When the steam is cooled, it condenses and the glove deflates.

c) Because of shaking the heat exchange is increased between the water and air in the jar. The hot air expands and inflates the glove. When the air is cooled, the glove deflates.

d) The shaking releases the gas dissolved in the water, as when the champion of a Formula 1 car race shakes the bottle of champagne.

e) The hot water affects the elastic properties of the glove.

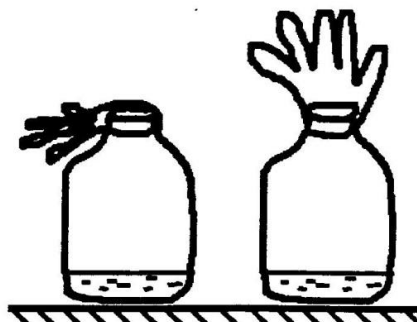

2. Answer: c) Because of shaking the heat exchange is intensified between the water and air in the jar. The hot air expands and inflates the glove. When the air is cooled, the glove deflates. The hot water in the jar can heat up the air above it by conduction of heat from the surface and vaporization from the surface. Neither is very efficient compared to the heat loss by conduction from the air inside the bottle to the room air - the surface area of the water is too small. So if nothing else is done, the air above the water is only slightly warmed. If you shake the bottle, the surface area is increased, the heat exchange is considerably increased, and the air becomes nearly the temperature of the water - expanding and inflating the glove. When the bottle is put down, the rapid conduction of heat to the air ceases, and the air cools again.

3. Question: Two point masses, A and B, are attached by threads to one support. The masses rotate about the vertical axis so that the threads circumscribe two different conical surfaces. Judging by the picture, which mass has greater period of rotation?

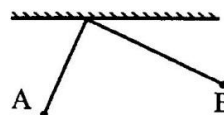

a) A

b) B

c) The information in the picture is not sufficient for definite answer. d) A and B have equal periods.

3. Answer: a) A

A mass orbiting on a string has a downward force $F = mg$, opposed by upward tension on the string. Because the mass is at constant height, the vertical component of the string tension must balance the weight, so the force exerted by the string is $mg/\cos(b)$. The inward component of that force, which causes the mass to go in a circle, is $mg \tan(b)$ where b is the angle from vertical of the supporting string. The radius of its orbit is $r = L \sin(b)$, where L is the length of the supporting cord. Its velocity in orbit is related to its acceleration by $a = v^2/r$. Substituting, one gets $F/m = g \tan(b) = v^2/(L \sin(b))$. Rearranging $v = \sqrt{gL/\cos(b)} \sin(b)$. The period of the orbit is $P = 2\pi r/v$.

Substituting, you find that $P = 2\pi L \sin(b) / (\sqrt{gL/\cos(b)}) \sin(b) = 2\pi \sqrt{L\cos(b)/g}$. $L \cos(b)$ is the distance of the mass below the support. So the lowest mass has the longest period.

4. Question: If a stone is dropped from a cliff into a lake 100 feet below, the impact will be heard how many seconds later? (1 foot = 30.5 cm).

- a. 0.1
- b. 1.3
- c. 2.5
- d. 2.6
- e. 3.9

4. Answer: d) 2.6 seconds

Get the time taken for stone to fall 100 ft from $\text{Dist} = \frac{1}{2} g T^2$, which becomes $T = \sqrt{2\text{Dist}/g} = \sqrt{2 \cdot 100 \text{ ft} / 32 \text{ ft/s}^2} = 2.5 \text{ sec}$. The sound of the splash travels at 1000 ft/sec, so takes 0.1 sec to get back to the top of the cliff, total time 2.6 sec.

5. Question: Two identical glasses contain: first milk, the second one the same volume of water. A spoon of milk is taken from a first glass and mixed up with the water in the second glass. Then by the same spoon the same volume of mixture is returned to the first glass. Which concentration is now larger: of water in the milk or of milk in the water? (Do not be confused by the fact that the milk always contains water; regard the milk as a uniform substance).

- a) There is more milk in water than water in milk
- b) There is more water in milk
- c) Concentrations are equal

5. Answer: c) The concentrations are equal For simplicity, assume initial volume of each container is 1, and that of the spoon is f . Remove a volume f from the first (water) container and put it in the second (milk) container. The first container now has volume $1-f$ of water. The second container has a total volume $1+f$, which contains a fraction $1/(1+f)$ milk and $f/(1+f)$ water. Now remove f from the milk container. Only $1/(1+f)$ of the f is milk. So I take out a volume $f \cdot 1/(1+f)$ of milk, and $f \cdot f/(1+f)$ of water. So the second container now has $1 - f/(1+f) = 1/(1+f)$ of milk and $f - f^2/(1+f) = f/(1+f)$ of water. Putting that second spoonful into the first container gives $(1-f) + f^2/(1+f) = (1-f^2)/(1+f) + f^2/(1+f) = 1/(1+f)$ of water and $f/(1+f)$ of milk.

6. Question: In the square of integer A the tens digit is 7. What is the units digit of A^2 ?

- a) 1
- b) 3
- c) 4
- d) 6
- e) 8
- f) 4 or 9
- g) 6 or 9

6. Answer: d) 6

Take $A = b + 10c + 100d \dots$, where b, c, d , etc are single digits. In $A^2 = b^2 + 2bc \cdot 10 + c^2 \cdot 100 + \dots$, only b and c contribute to the 10s place. The 10s digit of the $2bc$ term is even, so the 10s digit of the first term must be odd. That is only satisfied for $b = 4$ or 6 . In both cases, the units digit of A^2 will be 6 you can determine the numbers. If $b = 4$, $b^2 = 16$, and $2bc = 8c$. From that the ones digit of $8c = 6$ - ok for $c = 2$ or 7 . If $b = 6$, $b^2 = 36$, and $2bc = 12c$. From that the ones digit of $12c = 4$. Satisfied by $c = 2$ or 7 . So all 2 digit possibilities for A are 24, 74, 26, and 76.

Задание на заключительный тур

2nd US/Russian Internet Olympiad
April 27 (US), April 28 (Russia), 2000
Final Competition Problems
 (Questions on front of page, Solutions on back of page)

1. QUESTION

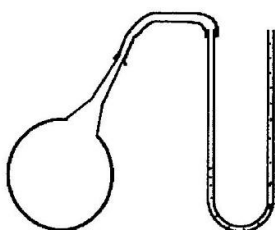

U – shaped tube is partly filled with water. Experimenter wants to displace the water out of the tube slowly and accurately, blowing the air into one of the tube legs through the rubber pipe. Initially the water flows out gradually as intended, but at certain moment it accelerates sharply and is ejected forming a fountain. The same takes place when the air is pumped from the rubber bulb. Explain this difference – why the displacement of water is gradual at the start and why it eventually becomes not controllable.

1. SOLUTION

Initially the driving pressure needed to displace water increases as displacement proceeds (the pressure drop is proportional to the difference in water column heights in the legs). Thus the displacement is stable. After the water in the left leg passes the lowest U point, the following displacement reduces the height (as well as weight) of water column. Meanwhile the air pressure does not fall appreciably, i.e. the net force upon the liquid column increases. This increasing force drives a steadily decreasing mass, so the acceleration increases. Finally the pressure drop which was enough to hold the water in the right leg, pushes quite small mass of water, which explains the fountain. (Similar effect occurs in the final stage of geyser eruption). The bubbles which might break through the water do not play a significant role because one can see that virtually all water is ejected.

2. QUESTION

A candle is placed in a clear jar and lit. A top is put on the jar and the candle remains burning for almost a minute and then goes out. The candle is removed from the jar, re-lit, and placed in an identical jar which has been standing open nearby. The top is put on as before and the jar is immediately dropped from about two meters above the floor. The candle is observed to go out before the jar hits the floor. Explain why the candle takes nearly a minute to go out in one case and less than one second in the other.

2. SOLUTION

The hot combustion products are less dense than the surrounding gasses. In the stationary jar there is a net upward force on the hot gas due to the difference in hydrostatic pressure (buoyancy) so the combustion products rise displacing air at the top of the jar. Fresh Oxygen is brought up from below to feed the flame. This effect called convection constantly mixes the air. The mixing and combustion continues until the Oxygen concentrations throughout the jar fall below that which is needed to support combustion. This takes nearly a minute for the jar shown.

When the jar falls freely, all parts are acted upon equally by gravity. All of the material in the jar falls together, including the candle, the air, the plasma (flame), and the combustion products. So within the jar the gravity is effectively switched off, the pressure is now the same in all parts of the jar, there is no buoyant force, and no convection. Without convection to mix the air, the flame quickly consumes the Oxygen nearby, and goes out.

3. QUESTION

A Yo-Yo having mass $M = 120$ grams is placed on an incline. From the bottom of the downhill side, the string is unwound and looped over a massless frictionless pulley where it is then secured

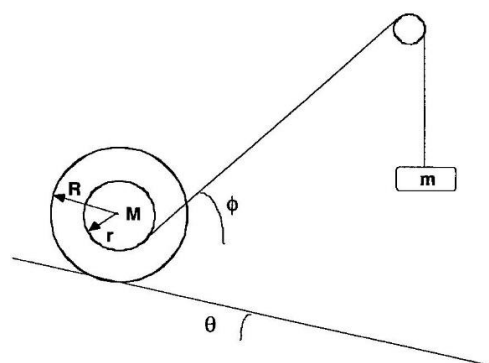

to a second mass ($m = 60$ grams). The incline is tilted to an angle of $\theta = 8.0^\circ$ and the coefficient of static friction between the incline and the Yo-Yo is $\mu = 0.67$. As the string is wound around the shaft of the yo-yo, the layers of string will increase the radius r of the outermost layer. Determine the angle ϕ made by the string when r is 50% of R and the system is in equilibrium. (Assume that the string is quite light, so that while r increases, no appreciable change is made to M .)

Is the equilibrium still possible if r increases to 75% of R ? If so, compute the equilibrium angle (ϕ) for the string. If not explain why.

3. SOLUTION

Part a. Writing the equilibrium for torque produces $Tr = FR$, where $T = mg = 0.5 Mg$ is tension, and F is the friction force up the ramp. Thus, $F = (r/R)T = 0.5T = 0.25 Mg$

Considering force components parallel, and perpendicular to the ramp produces:

$$T \cos(\theta + \phi) = F - Mg \sin(\theta) \tag{1}$$

$$N = Mg \cos(\theta) - T \sin(\theta + \phi) \tag{2}$$

Eliminating F and T in equation (1) gives:

$$0.5 Mg \cos(\theta + \phi) = 0.25 Mg - Mg \sin(\theta), \text{ or } \cos(\theta + \phi) = 0.5 - 2 \sin(\theta).$$

solving for ϕ gives:

$$\phi = \cos^{-1}(0.5 - 2 \sin \theta) - \theta = \cos^{-1}(0.5 - 2 \sin 8^\circ) - 8^\circ = 69.2^\circ.$$

For part b, $F = (r/R)T = 0.75T = 0.375 Mg$ and from (1)

$$\cos(\theta + \phi) = 0.75 - 2 \sin(\theta).$$

This equation still produces a number, $(\theta + \phi) = 61.86^\circ$; $\phi = 53.86^\circ$;

but the system will not be in equilibrium because it will slip first. To see this we find the ratio of friction to the Normal reaction force. From (2)

$$N = Mg \cos(\theta) - T \sin(\theta + \phi) = Mg (\cos(\theta) - 0.5 \sin(\theta + \phi)) = 0.549 Mg$$

$$\text{and } F/N = 0.375/0.549 = 0.683.$$

However, the maximum possible value for this ratio is the coefficient of friction, $\mu = 0.67$. Thus slipping will occur before the inner radius grows to $3/4$ of the outer radius. (For part a similar calculations give $N = 0.503 Mg$ and $F/N = 0.497 < \mu$).

Physically what happens is that the increased radius produces proportionally greater leverage for rotation by the string. The reaction force of static friction must grow to compensate. (This in turn requires that the orientation of the string be more horizontal to balance the larger friction force, so the angle ϕ is reduced). Just before the inner radius becomes 75% of the outer radius, the demand for the friction force exceeds the limit of static friction so slipping occurs.

4. QUESTION

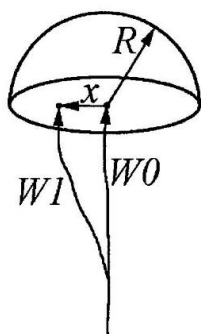

The surface of thin hollow hemisphere of radius R is charged uniformly, its total charge is Q . The point charge q of the same sign initially is very far from the hemisphere (at the infinity).

- Find the work $W0$ needed to move q to the center of the hemisphere.
- Find the work $W1$ to move the same point charge from infinity to the place in the edge plane of the hemisphere, whose distance from the center is $x < R$?

For both cases Q is fixed and does not migrate along the spherical surface.

4. SOLUTION

a). Work W_0 is equal to increase in the potential energy U of interacting charges. Initially U is zero, and if q is in the center, $U = kQq/R$ since all the hemisphere surface is at the distance R from q ; $k = 1$ (CGS units), $k = 1/4\pi\epsilon_0 = 9 \cdot 10^9$ (SI units).

b). To move the charge from center to x zero work is needed because the electric field within an edge plane is perpendicular to this plane. (Suppose the field has a component along radius. Add an identical hemisphere below to form closed shell, then there should be radial electric field inside. But it is known that inside the spherical uniformly charged shell the field is zero). Thus work $W_1 = W_0$, for any x (while $x < R$).

5. QUESTION

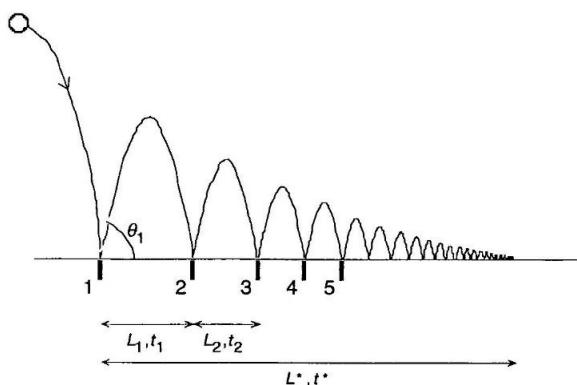

A ball is tossed onto the floor where it makes a succession of bounces as illustrated in the figure below. Assume that because of internal elasticity and friction with the floor at each bounce the magnitude of the vertical velocity component is reduced by a factor ϵ_y and the horizontal component is reduced by a factor ϵ_x . That is, if $v_{oy,n+1}$ denotes the y -component of the velocity as the ball emerges from the $(n + 1)$ st bounce, then $v_{oy,n+1} = \epsilon_y \cdot v_{oy,n}$, and similarly for the x -component. Note that ϵ_y

and ϵ_x are < 1 . Thus after each bounce, the ball moves slower and hops a shorter distance than it did after the preceding bounce.

Let the ball's succession of bounces traverse a total horizontal distance L^* which takes the time t^* . (As a practical matter, we measure L^* and t^* as the length and time where the bounces become imperceptible; mathematically, the number of bounces goes to infinity.) Find θ_1 , the angle the ball's velocity makes with the horizontal immediately after the first bounce, written in terms of L^* , t^* , ϵ_y , ϵ_x , and needed constants. Neglect air resistance.

5. SOLUTION.

$$\tan \theta_1 = \frac{v_{1y}}{v_{1x}} \text{ where } v_{1x} = \frac{L_1}{t_1} \text{ and } v_{1y} = \frac{1}{2} g t_1.$$

Thus we must find L_1 and t_1 in terms of the given quantities.

First let us find L_1 . The range of a bounce is $L_1 = v_{1x} t_1 = v_{1x} \left(\frac{2v_{1y}}{g} \right)$

The range of the second bounce is $L_2 = v_{2x} t_2 = \frac{2\varepsilon_x v_{1x} \varepsilon_y v_{1y}}{g} = \varepsilon_x \varepsilon_y L_1.$

The range of the third bounce is $L_3 = \varepsilon_x^2 \varepsilon_y^2 L_1.$

The total range is the $L^* = L_1 + \varepsilon_x \varepsilon_y L_1 + \varepsilon_x^2 \varepsilon_y^2 L_1 + \dots = L_1 \left(+\varepsilon_x \varepsilon_y + \varepsilon_x^2 \varepsilon_y^2 + \dots \right)$

or $L^* = L_1 (1 - \varepsilon_x \varepsilon_y)^{-1} \Rightarrow L_1 = L^* (1 - \varepsilon_x \varepsilon_y)$

Next let us find t_1 : $t_1 = \frac{2v_{0y}}{g}$ and $t_2 = \frac{2\varepsilon_y v_{0y}}{g} = \varepsilon_y t_1$ and $t_3 = \varepsilon_y^2 t_1$

Then $t^* = t_1 + t_2 + t_3 + \dots = t_1 \left(+\varepsilon_y + \varepsilon_y^2 + \dots \right) = t_1 (1 - \varepsilon_y)^{-1} \Rightarrow t_1 = t^* (1 - \varepsilon_y)$

Finally, $\tan \theta_1 = \frac{v_{1y}}{v_{1x}} = \frac{\frac{1}{2} g t_1}{\frac{L_1}{t_1}} = \frac{g t_1^2}{2 L_1} = \frac{g t^{*2} (1 - \varepsilon_y)^2}{2 L^* (1 - \varepsilon_x \varepsilon_y)}$

6. QUESTION

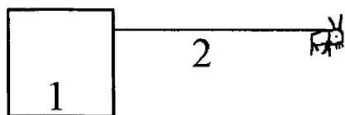

To the wall of square tower whose side is 1 the goat is attached by a rope of length 2 . The area of the lawn accessible for the goat changes depending on the place where the rope is fixed to the tower. Find the ratio between the maximal possible area to the minimal one.

6. SOLUTION

The goat always has a semicircle of radius 2 centered in the point where the rope is fixed to the tower, its area is 2π (to the right from the tower in the picture). If the distance from the fix point to the nearest corner is x , then a quarter of circle of radius $2 - x$ is accessible (above the tower in the picture), its area is $\pi(2 - x)^2/4$. Then a quarter of circle of radius $1 - x$, area is $\pi(1 - x)^2/4$ (to the left from the tower). If the goat goes clockwise, it can also consume $\pi(1 + x)^2/4$ below the tower and $\pi x^2/4$ to the left. Since the rope is not longer than half of the tower perimeter, these areas do not superimpose and can be simply summed up. Total area is $(\pi/4)(8 + (4 - 4x + x^2) + (1 - 2x + x^2) + (1 + 2x + x^2) + x^2) = (\pi/4)(14 - 4x + 4x^2)$. At $x = 0$ and $x = 1$ (fixed to the corner), the area is 14. When fixed to the middle of the wall (at $x = 0.5$), the area is 13. This is a minimum and 14 is a maximum (because of symmetry and positive coefficient at x^2). So the ratio is 14/13. The area can be written also as $(\pi/4)(13 + 4(x - 0.5)^2)$, from which the same result follows, perhaps more directly.

Публикации по поводу проведения Второй интернет-олимпиады по физике между российско-американскими командами в американской газете и в бюллетене Американского физического общества

Physics test spans the Web and world

Russian, U.S. students team up with their learning

By LISA STIFFLER
PI REPORTER

BELLEVUE — In an unusual collaboration that crossed cultures, U.S. and Russian high school students put their heads together over the Internet last week for a transcontinental physics competition.

Fifteen students from seven Washington schools gathered at Bellevue Community College to compete in the Internet Physics Olympiad 2000 with students in Russia.

The Washington students tackled problems sent over the Web, conversing with their international teammates in real time. They scribbled images on digitizing notepads that showed up instantly on the computer screens here and in Russia; they typed explanations about mass, pressure and acceleration in live chats.

Luckily, the Russians could con-

verse in English.

"I'm a typical American," said Paul Gibson, a senior from Davis High School in Yakima. "All I know about Russia is from 'Rocky' movies ... and Tom Clancy books."

But Thursday night, the students connected with their Russian peers, for whom it was Friday morning, bound by their shared passion for physics.

The competition, which also included high schoolers from San Diego, was between eight teams, each composed of four Americans and four Russians from St. Petersburg and Novosibirsk, a city in southern Siberia.

It was the second year of the contest, but the first time Washington students competed.

Chihiro Fukami, a senior from Issaquah High School, was curious about her foreign partners, and w-

from the participating sites.

Then the games began.

For each of six problems the students were given 12 minutes to come up with a solution, submitted in their native language. U.S. students from the three top scoring teams will receive electronic lab equipment for their schools from the Everett-based Fluke Corp. Russian prizes are yet to be determined.

There were some technical difficulties and final scores will be delayed until this week.

That wasn't much of a concern for participants.

"There's a lot of teamwork involved," Fukami said, "and that's more important than winning."

That's just what Boris Knyazev, chairman of the physics department at Novosibirsk State University and founder of the multinational contest, had in mind.

"This is a good opportunity for communication for high school students of different countries, because they must know each other better to

create ... a world where people do not conflict with each other," Knyazev said in a phone interview from San Diego.

There are tentative plans to hold the Olympiad again next year. The ultimate goal is to work out the technical bugs in the global community so other educators can connect students around the world for team problem-solving.

That sort of collaboration could have "wide application in all kinds of educational contexts," said Doug Brown, BCC physics instructor and Olympiad organizer.

Redmond High School senior Jason Mattax said he expects the international experience to be helpful in his future career.

Physics is "something that I want to do," Mattax said, "and not everyone (he'll encounter) is going to be American."

■ P-I reporter Lisa Stiffler can be reached at 206-448-8042 or lisastiffler@seattle-pi.com

Bull. Am. Phys. Soc., 2000, V.45, No.7, HP1 129.

**42nd Annual Meeting of the APS Division of Plasma Physics
with the 10th International Congress on Plasma Physics**

October 23-27, 2000

Quebec City, Canada

Session HP1 - Poster Session V.

POSTER session, Tuesday afternoon, October 24

Exhibit Hall AB, Quebec City Convention Centre

Internet Physics Olympiad - Round II

R. B. Stephens, C. A. Danielson (General Atomics), D. Brown, R. Hobbs (Bellevue Comm. College), A. V. Arzhannikov (Novosibirsk State U.), A. P. Ershov (Lavrentyev Inst. of Hydrodynamic), S. Halpern (Praja Inc.), B. Kniazev (Novosibirsk State U.), B. V. Kuteev (State Technical U.)

In April '00 high school students in Novosibirsk and St. Petersburg (Russia) combined with students in Seattle and San Diego (America) to participate in an internet-based science competition. Each of eight teams were composed of four American and four Russian students. Each pair of team halves were linked with their own private chat and whiteboard connection so they could consult in solving the problems. They were presented with questions and then submitted answers through an internet-based platform which was controlled at a central site; the system delivered each team's answers to separately located panels of judges. A running table of results was posted on the competition platform. This competition was an ambitious step up in complexity from the previous year's event. We demonstrated (in rudimentary form) that competitors from anywhere in the world can join in cooperative international competitions staged from a single high-technology hub.

Материал поступил в редколлегию
Received
21.02.2020